

COMPLETE RANGE OF FARM EQUIPMENT IN ONE PLACE



FARM TECHNOLOGY

JOMAPEKS

D.O.O.

NOVI SAD



Serbia, 21000 Novi Sad, Bul. Slobodana Jovanovića 34, Phone/Fax: +381 21 493-006, 493-757, 4791-757
E-mail: office@jomapeks.com, www.jomapeks.com

WATER HEATER NW 50 AGRO

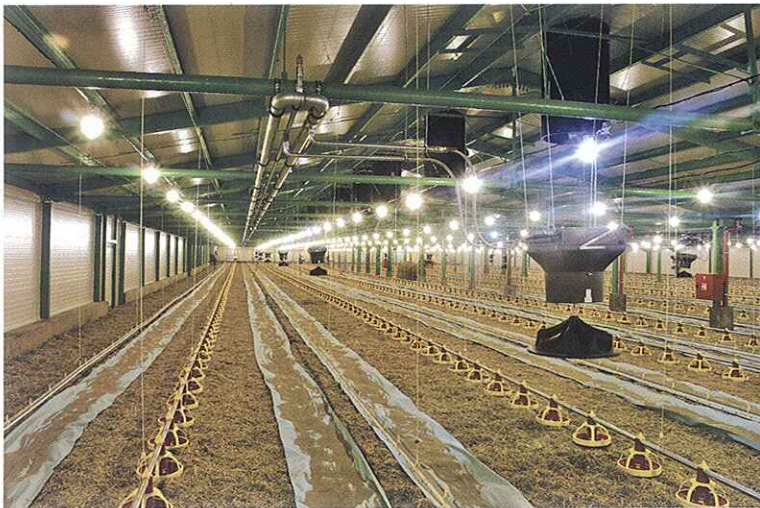

EXCANGER

The life and durability of the device is considerably increased during operation in aggressive environments owing to the application of the epoxidized exchanger. Wide gaps between lammellas facilitate cleaning.

FASTENERS

Easy access to the inside of the device by means of fasteners joining the exchanger and confusor, which shortens and facilities maintenance works.

THICKER LAMELLAS

40% thicker lamellas than in standard water heaters, more resistant to damages when cleaned with compressed air or high pressure water.

FAN

Increased water- and dust-proofness of the motor (IP66). Controlled with the speed regulator. Higher compression of the fan removes settling dust from the device.

- Innovative solution for livestock facilities
- Structure resistance to aggressive environments
- Can be cleaned with compressed air
- Low power consumption
- Reduces moisture level in a facility
- Can be heat-controlled
- Three-row heat exchanger
- Can be installed horizontally and vertically using a console
- Lowered CO₂ value on the litter level
- Does not utilize oxygen, does not produce CO₂

OPTIONAL ACCESSORIES

SPRAY NOZZLE



Designed for uniform distribution of hot air in a facility, forcing its circulation, and the heat flux is not directed at animals/plants.

MOUNTING BRACKETS



Facilitates removal and maintenance.



Spray nozzle lowered CO₂ value on the litter level.

Vertical installation

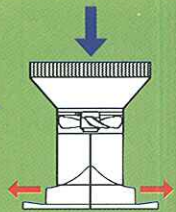

Horizontal installation

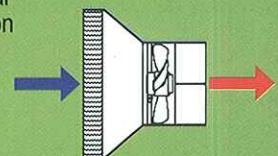

Air circulation in a horizontal installation

Installation

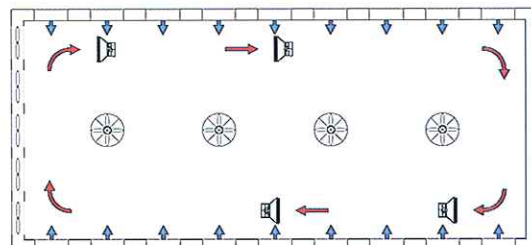
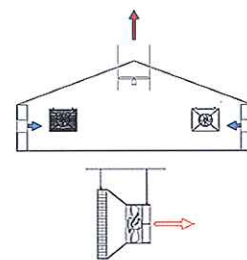
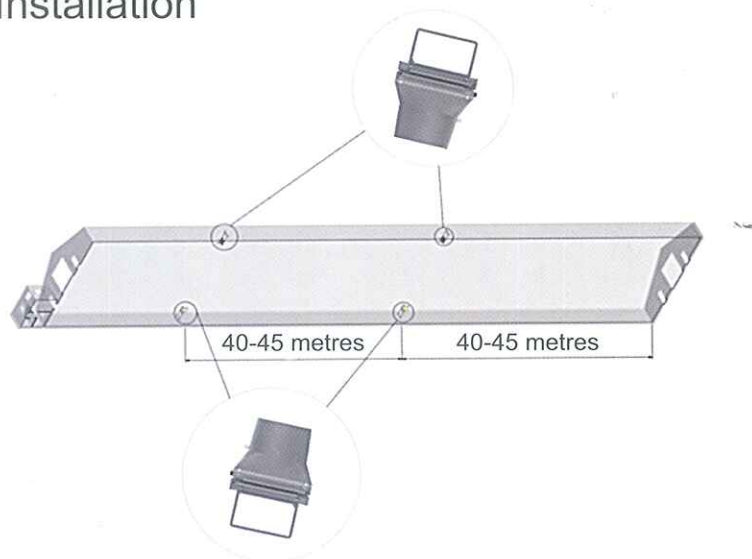

Air circulation in a horizontal installation

Air circulation in a vertical installation

Installation

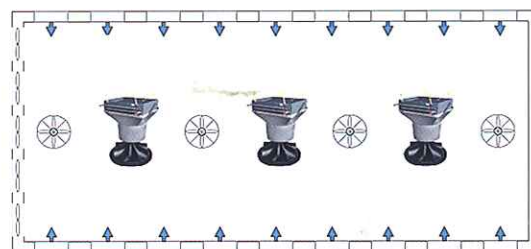
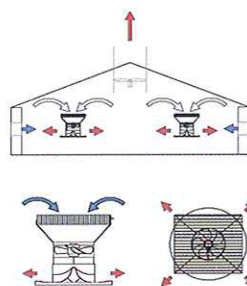
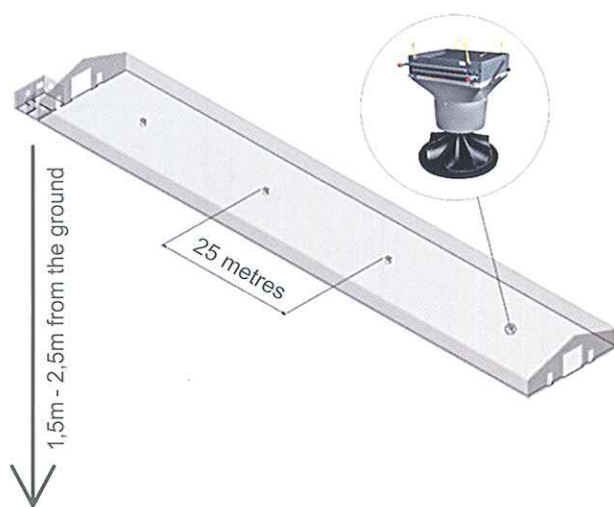

Air circulation in a vertical installation

Specification

Heat power	56,2kw	Power supply	230V/50Hz
Fan output	4.600m ³ /h	Max. power consumption	2,8A
Max. range of air stream	28m	Enclosure	ABS
Noise level	62dB(A)	Weight incl. water	28,7kg
Max. water temperature	95°C	Width	690mm
Max. water pressure	1,6MPA	Depth	625mm
Exchanger connector diameter	¾"	Height	660mm

